

- 1.1 The tank is labeled with a maximum burial depth which is to be measured from the grade to the top of the tank. If the tank is to be buried deeper, contact the tank manufacturer.
- 1.2 The bottom of the excavation shall be covered with a minimum of 12 inches (305 mm) of bedding, suitably graded and leveled. Bedding and backfill material surrounding the tank, to a width and depth of 12 inches (305 mm) all around the tank, shall be clean material.

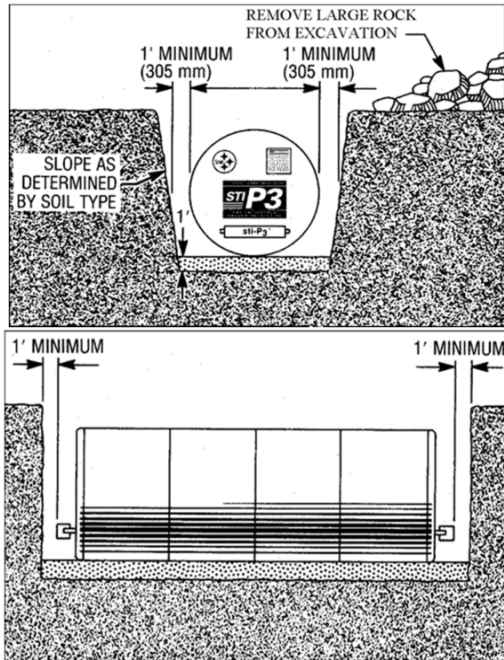

- 1.3 Where anchoring by means of a concrete pad, the tank shall not be placed directly on the pad. Bedding material at least 6 inches (152.4 mm) deep must be spread evenly over the dimensions of the pad to separate the tank from the pad.
- 1.4 Bedding and backfill material shall consist of homogenous pea gravel, crushed stone, clean sand, natural earthen materials, or excavatable flowable fill. Crushed stone, clean sand and natural earthen materials shall be capable of passing 100% through a 1/2 inch (13 mm) sieve and no more than 12% by dry weight through a #200 sieve (0.0029 inch (0.0754 mm)). Pea gravel shall be no larger than 3/4-inch (19 mm). Flowable fill shall meet the National Ready Mixed Concrete Association for Controlled Low Strength materials (CLSM) with strength ranging from 70-150 psi and shall be installed in accordance with good engineering practice. The materials shall be free of all foreign materials, such as but not limited to, bricks, metals, concrete and plastics.
- 1.5 The backfill material may be from the tank site if it meets this description, or it may be delivered to the site from another source.
- 1.6 Sand or natural earthen materials used as backfill shall be placed into the excavation in 12-18 inch (305-458 mm) vertical lifts, compacted after each lift, at least 60% up the vertical height of the tank.
- 1.7 If earthen material from the site, or other earthen material, is to be used as bedding or backfill material, a minimum of four 1 cu.ft. samples shall be taken from different locations which are representative of the backfill material and the site. Samples shall be sieved to determine if the material complies with this specification.
- 1.8 In a tidal area, the tank "bedding" material shall be crushed stone or pea gravel. Sand and natural earthen material may be used only if measures are taken to prevent washout of material during the design life of the system.

- 2.1 Temporary plugs and thread protectors installed by the manufacturer shall be removed. Apply compatible, non-hardening pipe sealant to internal bushing threads. Permanent metal plugs shall be installed at all unused openings.

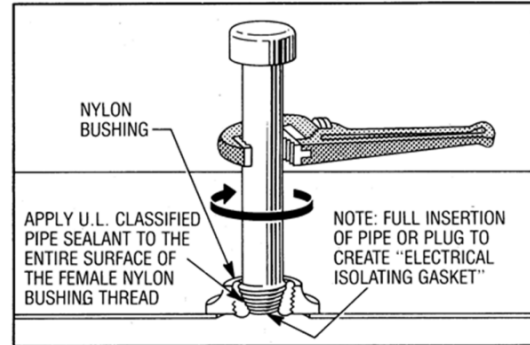

- 2.2 If the manufacturer has shipped a double wall tank with a vacuum on the interstitial space, read and record the vacuum pressure. If the vacuum gauge reading has dropped more than 2 inches Hg (6.77 kPa), from the level at which it was shipped, contact the tank manufacturer.
- 2.3 To conduct a soap solution/air pressure test, follow these steps:
 1. The nylon bushings in sti-P3® tanks shall not be removed from the unused openings. Plugs used to temporarily seal the tank for the above ground air test, but later removed for pipe installation, shall not be over tightened. Do not cross thread or damage the nylon bushings when replacing plugs or installing required tank piping.
 2. Test pressure shall be maintained at, without exceeding, 5 psig (34.47 kpa) while a soap solution is applied to the area of pipe connections and welds.
 3. Dual wall tanks shall require different air pressure testing procedures. Do not connect a high pressure air line directly to the interstitial monitoring port. A factory applied vacuum within the interstitial space can be used in lieu of, or in addition to, the air test procedure. Consult tank fabricator for air test recommendations. Do not apply a vacuum to the primary tank or a single wall tank. PEI/RP 100-00 also provides guidelines.
 4. Take necessary safety precautions during air tests. Do not leave tanks unattended. Avoid standing at the head of the tank, especially while applying air pressure. Use an air-pressure relief valve.

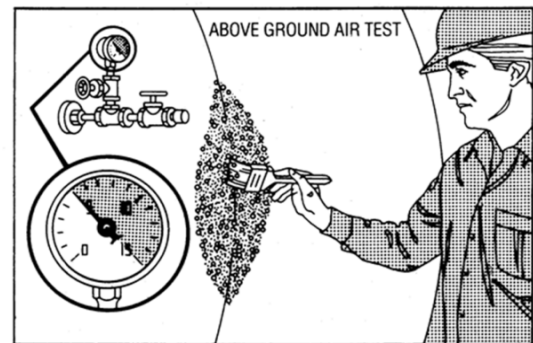

- 2.4 In lieu of the air pressure test described above, a vacuum may be applied to the interstice of a double-wall tank. DO NOT APPLY A VACUUM TO THE PRIMARY TANK OF A DOUBLE-WALL TANK OR TO A SINGLE-WALL TANK. A vacuum of 6 inches Hg (20.3 kPa) is to be applied to the interstice. The vacuum shall be held without a loss for one hour on tanks less than 20,000 gallons and for 2 hours

for tanks greater than or equal to 20,000 gallons. If this vacuum cannot be held for the specified time interval, then perform the air test procedure described in section 2.3.

3.0 COATING INSPECTION

- 3.1 Before placing the tank in the excavation, all dirt clods and similar foreign matter shall be cleaned from the tank, and areas of coating damage shall be repaired with touch-up coating kit provided.
- 3.2 Clean damaged coating areas through removal of surface rust, dirt, contaminants and disbonded coating prior to application of touch-up coating (see SSPC SP-2 "Hand Tool Cleaning" or SP-3 "Power Tool Cleaning" for additional guidance).

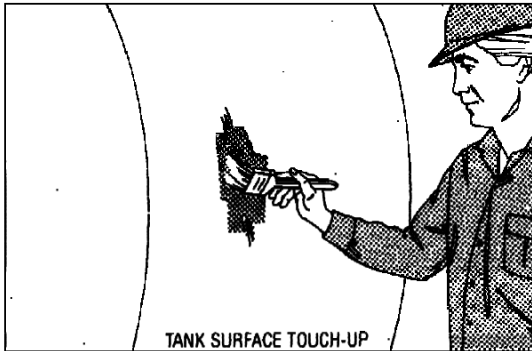

4.0 TANK HANDLING & PREPARATION

- 4.1 Controlled off-loading of the tank shall be allowed.
- 4.2 Equipment to lift the tank shall be of adequate size to lift and lower the tank without dragging or dropping to ensure there is no damage to the tank or the coating.
- 4.3 Tanks shall be carefully lifted and lowered by use of cables or chains of adequate length attached to the lifting lugs provided. A spreader bar shall be used where necessary. Under no circumstances shall chains or slings be used around the tank shell.

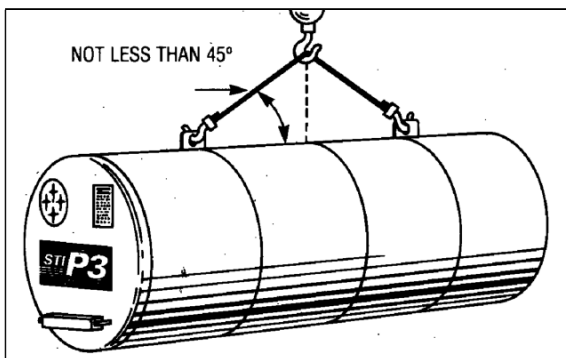

- 4.4 Follow label instructions including those at tank openings.
- 4.5 This tank requires venting. Refer to applicable local codes and PEI RP-100 for proper installation.

5.0 ANODE INTEGRITY

- 5.1 sti-P3® tanks may be equipped with either zinc or magnesium anodes. Whereas magnesium anodes are designed only for installation in soil resistivities of 2000 ohms-cm or greater, zinc anodes are effective in all soil resistivities.
- 5.2 After a sti-P3® tank has been placed in the excavation, if anode is connected by a lead wire, attachment to the tank shall be checked to assure this connection has not been damaged. Where damaged, the connection must be re-established in strict accordance with this specification.

- 5.3 After an sti-P3® tank has been placed in the excavation, if anode is connected by a lead wire, attachment to the tank shall be checked to assure this connection has not been damaged. Where damaged, the connection must be re-established in strict accordance with this specification.

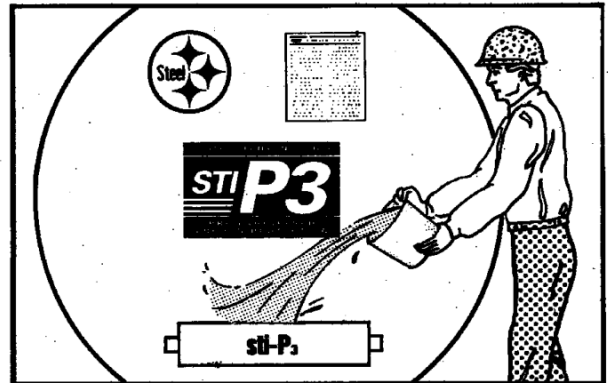

- 5.4 To assure immediate operation of cathodic protection system, each anode shall be thoroughly saturated with water at time of backfill operations.

6.0 ANCHORING

- 6.1 High water tables or partially flooded excavation sites exert significant buoyant forces on tanks. Buoyant forces are partially resisted by the weight of the tank, the backfill and the pavement atop the tank. Additional buoyant restraint, when required, shall be obtained by using properly designed hold-down straps in conjunction with concrete hold-down slabs or deadman anchors. The use of steel cable and/or round bar as hold-down straps on the tank is prohibited.
- 6.2 If a metallic hold-down strap is used, a pad of inert insulating dielectric material must be used to insulate the hold-down strap from the tank. The separating pad shall be wider than the hold-down straps, which will prevent direct contact between the straps and the tank shell. This pad is not required if the hold-down strap

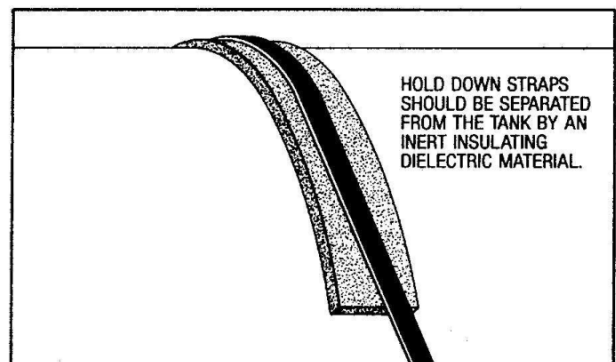

- 6.3 Ballasting the tank may be necessary. When water is used as the ballast material, it shall only be potable water and shall not remain in the tank longer than 60 days. During construction, adequately vent all tank spaces. If product is used as ballast, proper precautions must be taken to prevent fires, spills, leaks, and other associated accidents. Monitor product level frequently to ensure there has been no unaccounted loss of product. Do not over tighten hold-down straps beyond snug and do not re-tighten hold-down straps after ballasting.

7.0 BACKFILL

- 7.1 Homogeneous backfill similar to bedding material shall be placed carefully around the entire tank to create a uniform homogeneous environment. Avoid damage to coating especially where tamping is required.
- 7.2 Installing and tamping backfill along the bottom sides of the tank shall ensure that the tank is fully and evenly supported around the bottom quadrant.

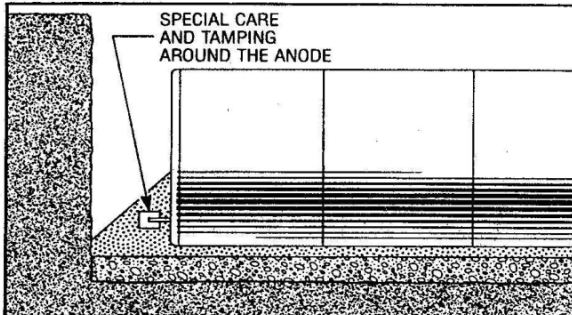
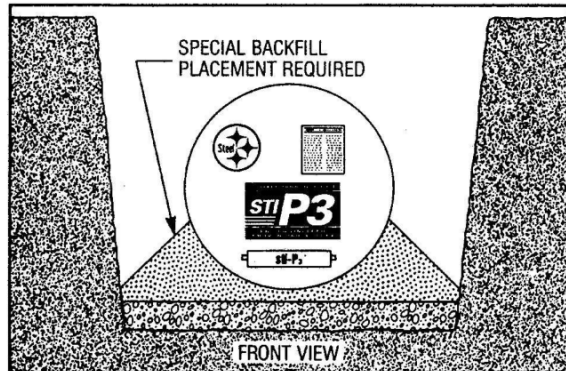

- 7.3 Prior to backfilling to top of tank, all openings shall be visually inspected to assure that the sti-P3[®] nylon bushings remain in place. Where flanged openings have been used, isolation of the flange gaskets shall be confirmed with a continuity tester. No current shall pass through the factory installed flange gaskets. Isolation of the fittings is required to assure tank integrity. If the tank is to be installed in the presence of an impressed current system, the effect of the system must be considered on the sti-P3[®] tank. The corrosion consultant must consider including the sti-P3[®] tank into the design of the impressed current system.

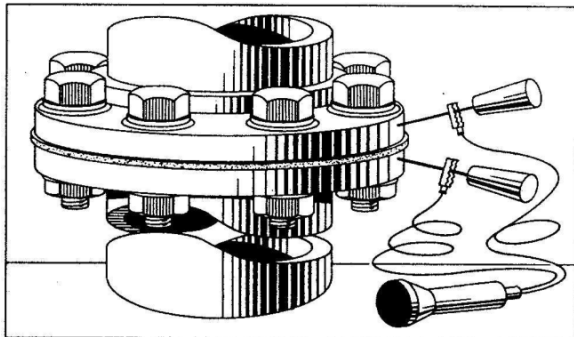

8.0 FINAL AIR TEST

- 8.1 Install required tank piping using compatible non-hardening sealant, taking care not to cross thread or damage the non-metallic bushings. Torque of 400 to 1,000 ft-lbs (542.3 to 1355.8 N-m) may be required to fully insert pipe.
- 8.2 Where air or hydrostatic testing is required after installation, the pressure applied shall not be in excess of 5 pounds per-square-inch (34.5 kPa) as measured at the top of the tank. A soap solution shall be applied around pipe connectors while air test is being performed.

9.0 TANK MONITORING SYSTEM INSTALLATION

- 9.1 Each tank shall have a cathodic protection monitoring station (PP4[®], PP2[®], PP1[®], or other) installed in such a way so that there will be at least a tank structure lead easily accessible and identifiable at the finish grade and provide easy placement of a reference electrode during monitoring.
- 9.2 If your tank is equipped with a Protection Prover 4 (PP4[®]), remove the unit from the shipping carton and inspect for damage. (See the separate manufacturers' installation instructions for specific details.)

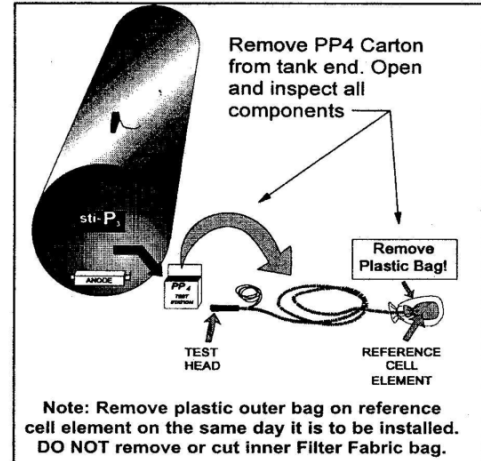

- 9.3 Prior to installation of the PP4[®], remove the plastic bag from the reference cell element. After the tanks have been placed in the excavation, position the reference cell element midway from front to back between two tanks so that it is covered by 6 inches (152 mm) of moist bedding material.

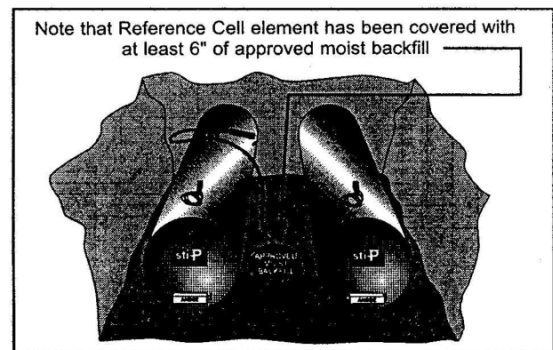

- 9.4 Drape the flexible pipe up to the top of the tank and temporarily secure the pipe to prevent damage during backfill operations. Backfill the excavation until the tanks are almost covered.
- 9.5 Locate the PP4[®] test head in its approximate final position and support with a wooden stake or other similar device. Connect the appropriate tank test wire from the reference cell element to the black test lead already installed on the tank using the hardware supplied or by performing a field splice.
- 9.6 Assure that the wire connection is strong by simultaneously placing tension on the wire at either side of the connection point. Protect the wire connection from corrosion using the material supplied with the PP4[®] or by wrapping the connection in half lapped layers of rubber and PVC electrical tape.

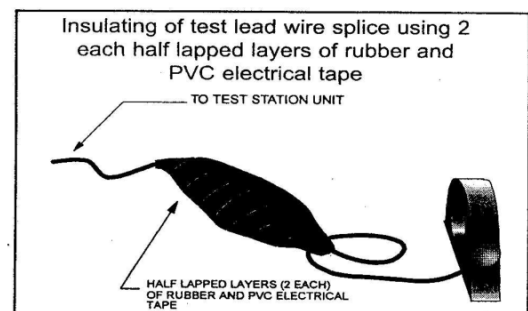

- 9.7 Assure that the wire connection is strong by simultaneously placing tension on the wire at either side of the connection point. Protect the wire connection from corrosion using the material supplied with the PP4® or by wrapping the connection in half lapped layers of rubber and PVC electrical tape.
- 9.8 The test head shall be placed in a small grade manhole to protect it from vehicular traffic or set directly in the concrete covering for the excavation. During pouring of the at-grade slab protect the metal contact points on the test head from being covered by concrete.
 1. Select a terminal location on a pipe near grade that will be accessible through a grade manhole upon completion of installation.
 2. Loosen the black nylon pipe lashing by releasing the locking tab. Uncoil enough lead wire from the tank mounting lug to reach the terminal location with an additional 4 feet (1.2 m) of slack.
 3. Secure the PP2® terminal to the pipe by tightening the black nylon pipe lashing. The lead wire terminations shall remain sealed.
 4. Route wire to avoid strain or breakage during backfill. Do not cover PP2® terminal with backfill material.

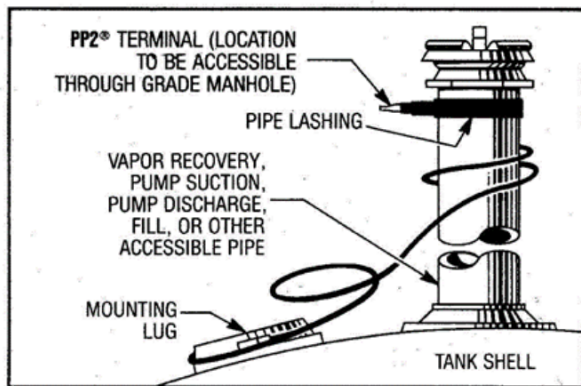

- 9.9 If the tank is equipped with a Protection Prover 1 (PP1®) monitoring system, which includes a monitoring test station mounted at the end of the tank, prior to any backfilling, extend the monitoring system to 4 inches (102 mm) below grade level without pulling it out of the mounting bracket. The PP1® test station shall be protected by a grade manhole of 7½ inches (191 mm) minimum diameter.

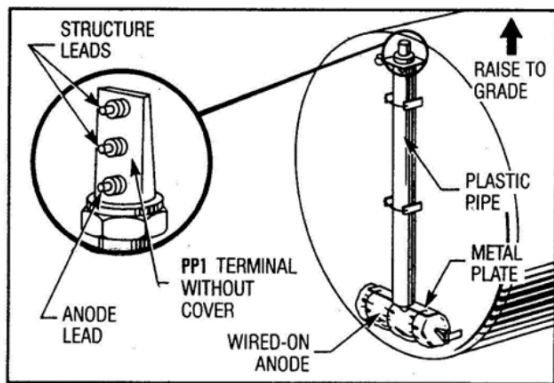

10.0 ELECTRICAL CONTINUITY TEST

- 10.1 Contact between the steel tank and all other structures such as external and internal piping, pumps, valves, gauge, and monitoring equipment, and grounding systems, will nullify the cathodic protection design. Prior to backfill, a simple continuity test between the tank lead wire and each connected system will verify the electrical isolation. Continuity shall not be present. After backfill, continuity can be checked with a high impedance voltmeter by fixing a copper/copper sulfate reference cell in the soil and contacting all structures with the other voltmeter lead wire. Do not move the reference cell. Potential differences between the tank to soil and all other structures to soil must exceed 10 millivolts to verify electrical isolation.

11.0 FINAL BACKFILL

- 11.1 Homogeneous backfill shall be deposited carefully around the tank and to a depth of at least one foot (305mm) over the tank. (See NFPA 30 and state or local codes for minimum depth of cover required).

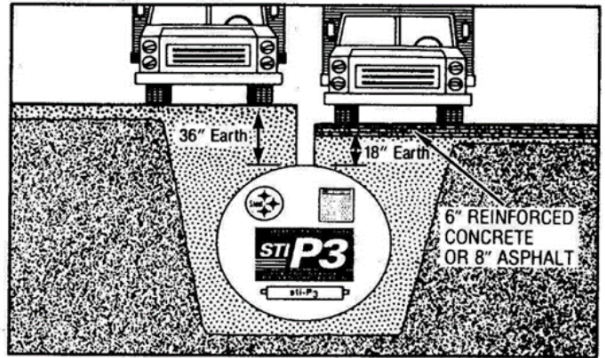

12.0 POST-INSTALLATION CATHODIC PROTECTION MONITORING

- 12.1 All tanks must be monitored to assure proper installation and ensuing cathodic protection of the tank. Before pouring concrete or asphalt pad atop tank, a tank to soil potential reading with a high impedance voltmeter and copper/copper sulfate reference electrode must be taken. Reference electrode shall be placed in moist soil directly above the tank. A minimum reading of -850 millivolts should be obtained to indicate that the tank anodes are activated. Record reading on installer information card and other permanent files.

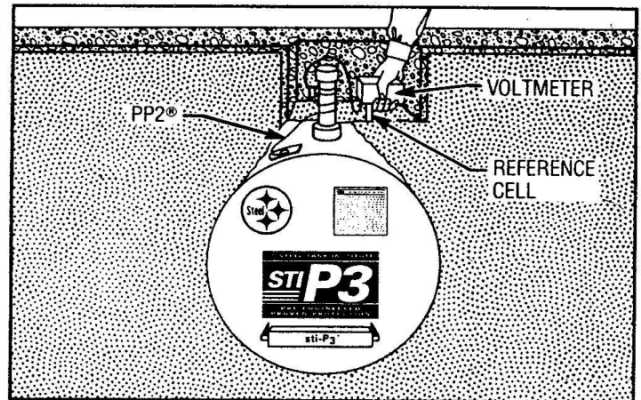

- 12.2 If the tank is connected to a PP4® test station the cathodic protection can be easily verified using a high impedance digital volt-meter. Touch the meter probes to the appropriate test head terminals as shown in the diagram above. As stated in 12.1, a minimum reading of -850 millivolts should be obtained.

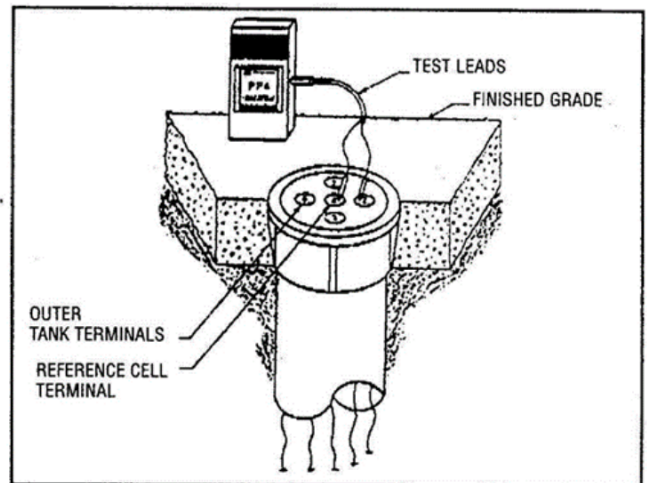

13.0 OPERATING LIMITATIONS

Operation of the tank above 120°F (49°C) requires the use of specific components and materials. The tank manufacturer must be notified, prior to tank use, of the owner's intent to operate this tank above 120°F (49°C) so that proper components and materials can be incorporated.

- 13.1 When the product stored is heated, the temperature inside the tank shall be constantly monitored to assure the maximum allowable temperature is not exceeded.

14.0 MAINTENANCE

- 14.1 The primary tank shall be inspected monthly for the presence of water. Inspection shall take place at the lowest possible points inside the primary tank. Remove any water found. Water and sediment in fuel can cause plugging of filters. Also, bacterial growth, originating from the fuel can cause filters to plug and corrosion of tanks and lines. For procedures on how to check for the presence of water and removal of water, refer to STI R111, Storage Tank Maintenance. For copies of the RP and more information, please go to www.steetank.com.
- 14.2 sti-P3® tanks shall be tested for cathodic protection at installation, in 3 year intervals for the life of the installation and after any activity that might affect the CP system. sti-P3® tanks which might otherwise be classified as ACT-100® composite tanks, due to factory attachment of anodes, do not require testing every third year. In addition, double-wall sti-P3® systems that use interstitial monitoring that is capable of detecting a breach of either tank wall, do not require testing every third year. (See EPA UST technical Compendium for complete details www.epa.gov/swerust1/compend/nus18lh.pdf). Follow applicable local, state, and federal regulations for any additional requirements. Reference NACE RP-0285 for more specifics on protection criteria.
- 14.3 Tank must be installed within one year of delivery from tank manufacturer. If tank is not installed within this time period, contact tank manufacturer to recertify the tank.
- 14.4 Safety considerations and controls should be established prior to undertaking physical activities associated with USTs. Some hazards associated with USTs are, but not limited to, confined space entry, cleaning, inspection, moving and any other aspect of in-service work.
- Contact tank manufacturer before moving tank for information on recertifying tank for continued use.

Disclaimer

These instructions are intended only as an aid to tank installers who are knowledgeable and experienced in underground tank installation. Compliance herewith does not necessarily meet the requirements of applicable federal, state and local laws, regulations and ordinances concerning tank installation. STI makes no warranties, express or implied, including but not limited to, any implied warranties of merchantability or fitness for a particular purpose, as a result of these installation instructions.

Contact STI for the latest version of these Installation Instructions or visit the STI website at www.steetank.com.



Structural Tank Equipment & Maintenance (Canada) Limited

ISO 9001: Registered (10012564 QMI5)

Structural Tank Equipment & Maintenance (Canada) Limited

69 Comstock Road
Scarborough, ON M1L 2G9

Phone: 416-757-6278 Toll Free 1-800-387-1400

Location of Tank: _____

Date: _____

HANDLING CHECK () CHECK ()

The handling equipment is of adequate size and capacity to lift and lower the tank without dragging or dropping _____

The repair of any damaged laminate areas has been made in accordance with installation instructions _____

Plastic wrap has been removed from the weld-on zinc anode _____

EXCAVATION

The site has been excavated deep enough to enable 1 foot of compacted clean sand or gravel to act as bedding material between native soil and tank when anchoring is not required _____

Burial depths meet minimum code requirements (such as NFPA 30). _____

NOTE: Check with tank manufacturer when burial depth exceeds 5 feet. Steel thickness can be calculated for the required burial depth.

TESTING

The tank has been air-tested at 5 psig (kPa) while applying soap solution onto weld seams and fittings to check or leaks OR _____

A vacuum test has been performed in accordance with the fabricator's instructions _____

All local and state testing requirements have been performed _____

ANCHORING (check one)

Not applicable to this site _____

Deadman anchors used _____

Concrete pad _____

Soil and pavement overburden will hold down tank (Reference PEI/RP 100) _____

When anchoring with a concrete hold down pad, a minimum 6 inch (152.4 mm) layer of pea over the concrete pad dimensions to separate tank from pad _____

When deadman anchors or hold down pads are used, hold down straps have been separated from the tank by an inert insulating dielectric material at least 1 inch (25.4 mm) wider than the steel hold down straps _____

Tank is electrically isolated from the hold down strap. _____

BACKFILL

Homogenous backfill consisting of clean sand, pea gravel, #8 crushed stone or material earthen material has been used _____

Backfill is the same material as bedding _____

Backfill has been placed along sides of tank to ensure full support along the tank's bottom quadrant _____

PIPE CONNECTIONS

Electrical isolation of flanged connections has been verified with a continuity tester. _____

Prior to backfilling over tank top, but after piping to the tank, electrical isolation of tank from all equipment has been verified. _____

No continuity shall be present. _____

TANK MONITORING

The cathodic protection monitoring station has been installed and brought to grade and access to the soil above the tank has been provided _____

Verify operation of the cathodic protection system by: A tank to soil potential reading obtained with a high impedance voltmeter and a copper/copper sulfate reference electrode installed with the tank or placed immediately above the tank in soil.

Record reading: _____ mV

The tank owner has received the above information _____

All other facets of tank installation have been made in accordance with sti-P3® instructions _____

Signature and Title of Installing Foreman and/or Project Engineer

Signature and Title of Installing Contract

Note: This checklist includes certain key steps in the proper installation of the sti-P3 tank and is intended only as an aid to tank installers who are knowledgeable and experienced in underground tank installation. Compliance herewith does not necessarily meet the requirements of all applicable federal, state, and local laws, regulations and ordinances concerning tank installation.